

Member



The PD1600 Series Inverters are 120 VAC, 60 Hz, pure sine wave inverters with integrated transfer switch. Available in 1000W, 1800W, and 2000W models, the PD1600 Series Inverters have been robustly designed with safety and protection features for installation in recreational and commercial vehicles. With a built in transfer switch this inverter can switch seamlessly between inverter power and external shore power without any power interruptions. It has been UL458 certified in both the US and Canada so you can feel comfortable knowing that your inverter is safe.

With the recreational and commercial vehicle industry in mind, the PD1600 Series Inverter was designed to be compact and light-weight to fit the strict size and weight constraints often found within vehicles. The improved thermal design reduces the ventilation space required, which contributes to a even smaller space requirement for your inverter.

Progressive Dynamics, Inc. has a complete line of power products for your commercial and recreational vehicle needs. PDI has existing product lines of Power Converters, Automatic Transfer Switches, AC Distribution Panels, and DC Distribution Panels. These product lines along with the newly introduced inverters make Progressive Dynamics the only part supplier you need to build a complete power system for your recreational or commercial vehicle. Our experienced sales and service department are available to help determine which power solutions are best suited to your needs.

Table of Contents

Introduction	3
Key Features	5
RV Power System	6
Installation Instructions	8
Display and User Interface	12
Troubleshooting.....	14
Technical Specifications	15
RV-C Connectivity Specification	16

LIMITED WARRANTY

- I. **LIMITED WARRANTY:** Progressive Dynamics Warrants its power inverters to be free from defects in material or workmanship under normal use and service; and limits the remedies to repair or replacement.
- II. **DURATION:** This warranty shall extend for a period of two years from the original date of purchase, and is valid only within the continental limits of the United States and Canada.
- III. **WARRANTY EXCLUSIONS:** This warranty does not apply to:
 - A. Any product which has been repaired or altered in any way by an unauthorized person or service station
 - B. Damage caused by excessive input voltage, misuse, negligence, or accident; or an external force
 - C. Any product which has been connected, installed, or adjusted or used other than in accordance with the instructions furnished, or has had the serial number altered, defaced, or removed
 - D. Cost of all services performed in removing and reinstalling the power inverter
 - E. ANY LOST PROFITS, LOST SAVINGS, LOSS OF USE OF ENJOYMENT OR OTHER INCIDENTAL DAMAGES ARISING OUT OF THE USE OF, OR INABILITY TO USE, THE PRODUCT. THIS INCLUDES DAMAGES TO PROPERTY AND, TO THE EXTENT PERMITTED BY LAW, DAMAGES FOR PERSONAL INJURY. THIS WARRANTY IN IN LIEU OF ALL OTHER WARRANTIES, INCLUDING WARRANTIES OF MERCHANTABILITY AND FITNESS FOR A PARTICULAR PURPOSES.
- IV. **PROOF OF PURCHASE:** A warranty claim must be accompanied by proof of the date of purchase.
- V. **CLAIM PROCEDURE:** Upon discovery of a defect, Progressive Dynamics shall be supplied the following information at the address listed below:
 - A. Name and address of claimant
 - B. Name, model, and serial number of the product
 - C. Application in which product was installed. (Includes manufacturer, model, and model year where applicable).
 - D. Date of purchase
 - E. Complete description of the claimed defect

Upon determination that a warranty claim exists (a defect in material or workmanship occurring under normal use and service) the inverter shall be shipped postage prepaid to Progressive Dynamics together with proof of purchase. The product will be repaired or replaced and returned postage prepaid.

Mail Returns to: Progressive Dynamics
507 Industrial Road
Marshall, MI 49068

For Warranty Service: service@progressivedyn.com

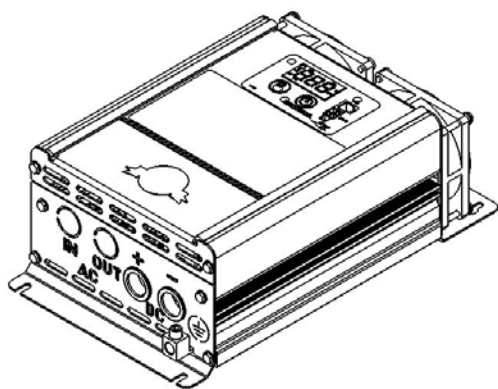

PD1610*
1000W Inverter

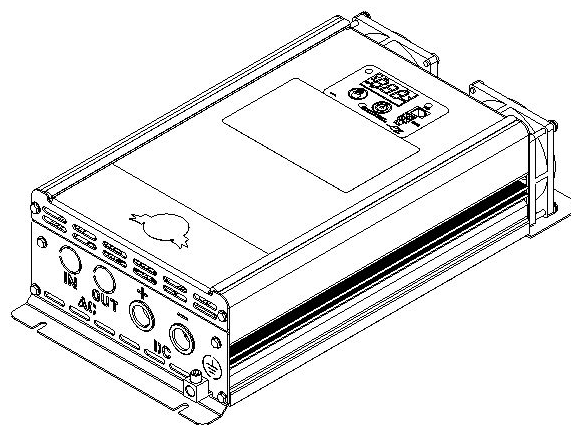

PD1618* **PD1620***
1800W Inverter 2000W Inverter

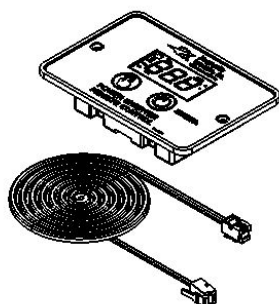

PD1601-25
25' Remote Display
(Included with unit)

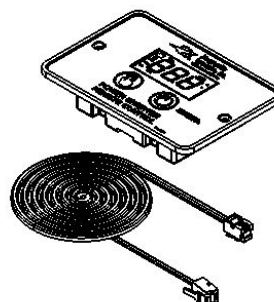

PD1601-50
50' Remote Display
(Sold Separately)

Figure 1 PD1600 Series Inverter Components

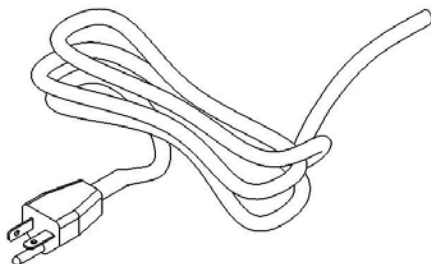

*Inverter units available with optional input power cord installed

All products include a quick reference guide with specifications and installation instructions

NOTE: If any of the items are missing, contact Progressive Dynamics for replacement.

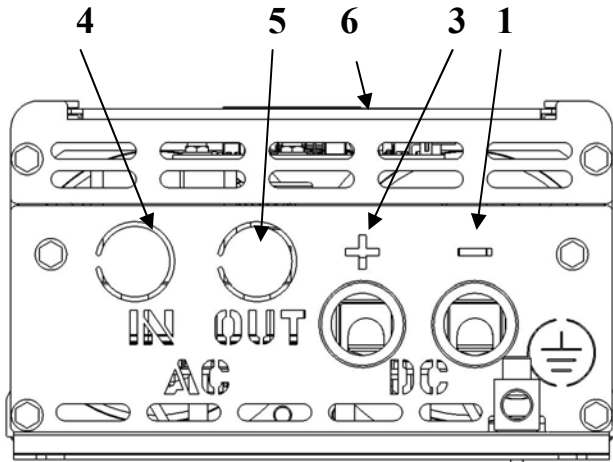

Figure 2 PD1600 Series Inverter (AC/DC End View)

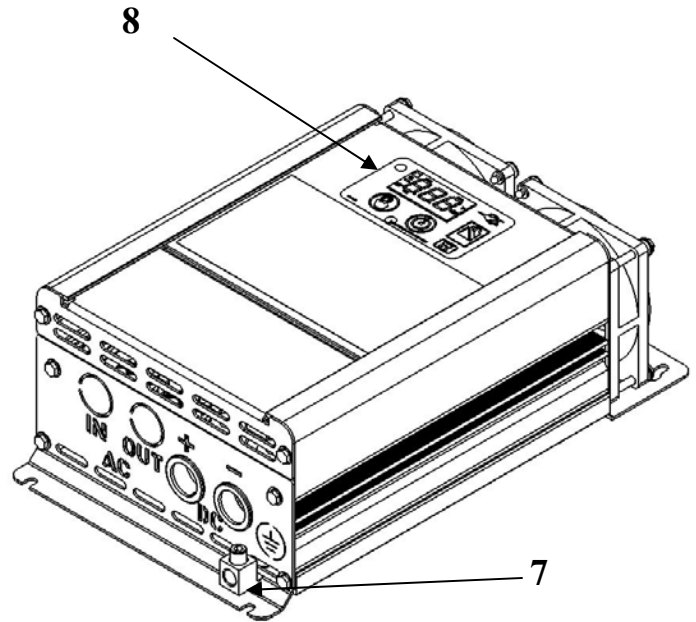

Figure 4 PD1600 Series Inverter (Isometric View)

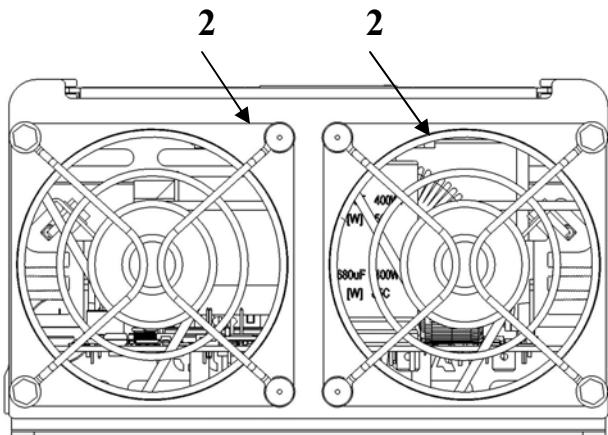

Figure 3 PD1600 Series Inverter (Fan End View)

Descriptions	
1	<u>DC Input Port (negative):</u> Used to connect to battery (-)
2	<u>Ventilation Input:</u> Ensure ventilation input is not blocked for proper operation
3	<u>DC Input Port (positive):</u> Used to connect to battery (+)
4	<u>AC Input Knockout:</u> Knockout to be removed when connecting transfer switch to external AC power
5	<u>AC Output Knockout:</u> Knockout to be removed when connecting to hardwired AC Output
6	<u>AC/DC Access Panel:</u> Remove access panel to wire install AC and DC wiring
7	<u>Equipment Ground Lug:</u> Connect case to earth ground to ensure proper, safe operation
8	<u>On-Board Display:</u> Display monitors all relevant parameters of the PD1600 Series Inverter

Key Features

Pure Sine Wave Output

The output of the PD1600 Series inverter is a 120 VAC, 60 Hz, pure sine wave. Unlike a modified sine wave, a pure sine wave is ideally suited to drive all types of loads including refrigerators, motors, power tools, and common household electronics.

Integrated Automatic Transfer Switch

Built into the PD1600 Series Inverter is an automatic transfer switch that engages whenever power is detected at the AC input port. In recreational vehicles this is often used to switch over to shore or generator power when it is available, reserving the battery power for later use. The transfer switch transition times are fast enough that transitioning from one source to another will not impede operation for most electrical loads.

Easy Installation

When designing the PD1600 Series Inverter special attention was paid to making it easy to install. The AC connection points are color co-ordinate push-in terminals. When hard-wiring your new inverter the installer can pull out the knockouts by hand, insert the Romex cable, then push each conductor into place. The DC connections are made directly to lugs instead of using large, expensive ring terminals. The only tool required is a 5/32" hex key.

2X Peak Power Rating

When starting inductive loads like compressors (found in common household refrigerators) there is a large surge in power draw during the initial startup. To supply this initial start up power the PD1600 Series Inverter has been designed to supply a peak power that is 2X its rated power.

Fully Functional Remote Display (Optional)

When purchasing your inverter an optional addition is the remote display. The PD1600 Series Inverter has an optional remote display that is fully functional at up to 50 feet away. This includes turning on and off the inverter and monitoring battery voltage and power consumption.

Hardwired AC Output

The PD1600 Series Inverter is designed to be being used with a hard-wired output. If a GFCI output on the inverter is required in your application investigate the PD1600 Series Inverters offered by Progressive Dynamics.

Automatic Restart After DC Disconnect

The PD1600 Series Inverter will detect when the battery input connections have been removed. When the DC disconnect switch is re-engaged the inverter will automatically restart. Similar to a DC disconnect switch, this automatic restart also kicks in when the user replaces the batteries. To avoid an automatic restart, simply turn off the inverter prior to disconnecting the batteries.

Under/Over Voltage Protection

To protect both the inverter and the battery bank the PD1600 Series Inverter has been designed with integral under voltage and over voltage protection. These voltage limits are designed to operate with a Lead-Acid battery bank without damaging the batteries. The inverter may also be used with a 12V lithium ion battery pack (LiFePO4) with a properly configured BMS. See Specifications on page 16 for voltage limits.

Reverse Battery Protection

Reverse battery protection has been added to the inverter to protect the equipment in the event that the positive and negative terminals of the battery are incorrectly connected to the inverter. Unlike some other inverters on the market, there is not a time delay associated with the reverse battery protection. In the event that the inverter is reverse wired it will not turn on.

Over-Load Protection

In order to protect the inverter from over-load conditions the power draw is continually measured and should it exceed the rated output power the inverter will automatically shutdown and display the error code corresponding to an over-load error. This is a required feature in all UL safety certified inverters.

Short Circuit Protection

In any power system, a sustained short circuit can cause hazardous conditions potentially resulting in over-heating and fire. To avoid these conditions the inverter has been designed with short circuit protection. It will detect any large current spikes caused by a short circuit and shutdown immediately to avoid damaging the inverter and output wiring.

Over Temperature Protection

A required feature for all UL safety certified inverters, over temperature protection is designed into every PD1600 Series inverter. When the internal temperature of the inverter gets too high due to poor ventilation or high ambient temperature the inverter will shutdown. The output will automatically turn back on when the internal temperature returns to safe operating temperatures.

Thermally-Controlled Variable Speed Fan

Using technology that is found in all Progressive Dynamics Converters, the PD1600 Series Inverter employs a thermally-controlled variable speed fan. This fan will only turn on when the inverter is operating at a warmer than normal temperatures. Furthermore, when it does turn on, the speed of the fan is smoothly controlled to only run as fast as necessary to keep the inverter within safe operating temperatures. This is designed to minimize disruptive audible noise

Neutral Bonding

In an RV the neutral should be tied to ground at the source of the power. To safely accomplish this the PD1600 Series inverter ties the neutral to ground only if the inverter is supplying the power. When the transfer switch is engaged to pass AC Input power, the ground connection is passed from AC input to AC output with the assumption that the neutral is properly grounded wherever the power is being generated (generator or campground electrical post).

The PD1600 Series Inverter in a 30A RV Power System

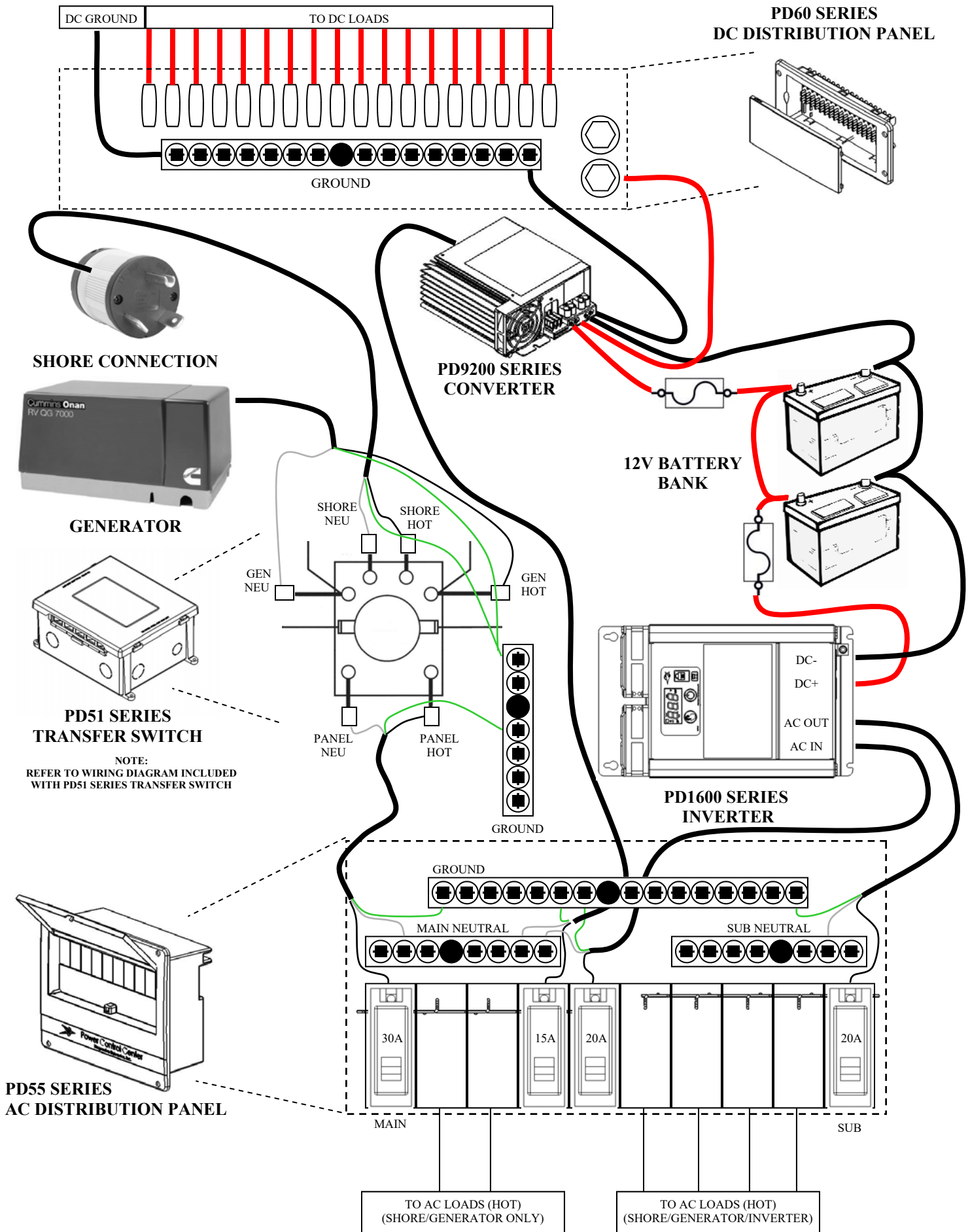

The PD1600 Series Inverter in a 50A RV Power System

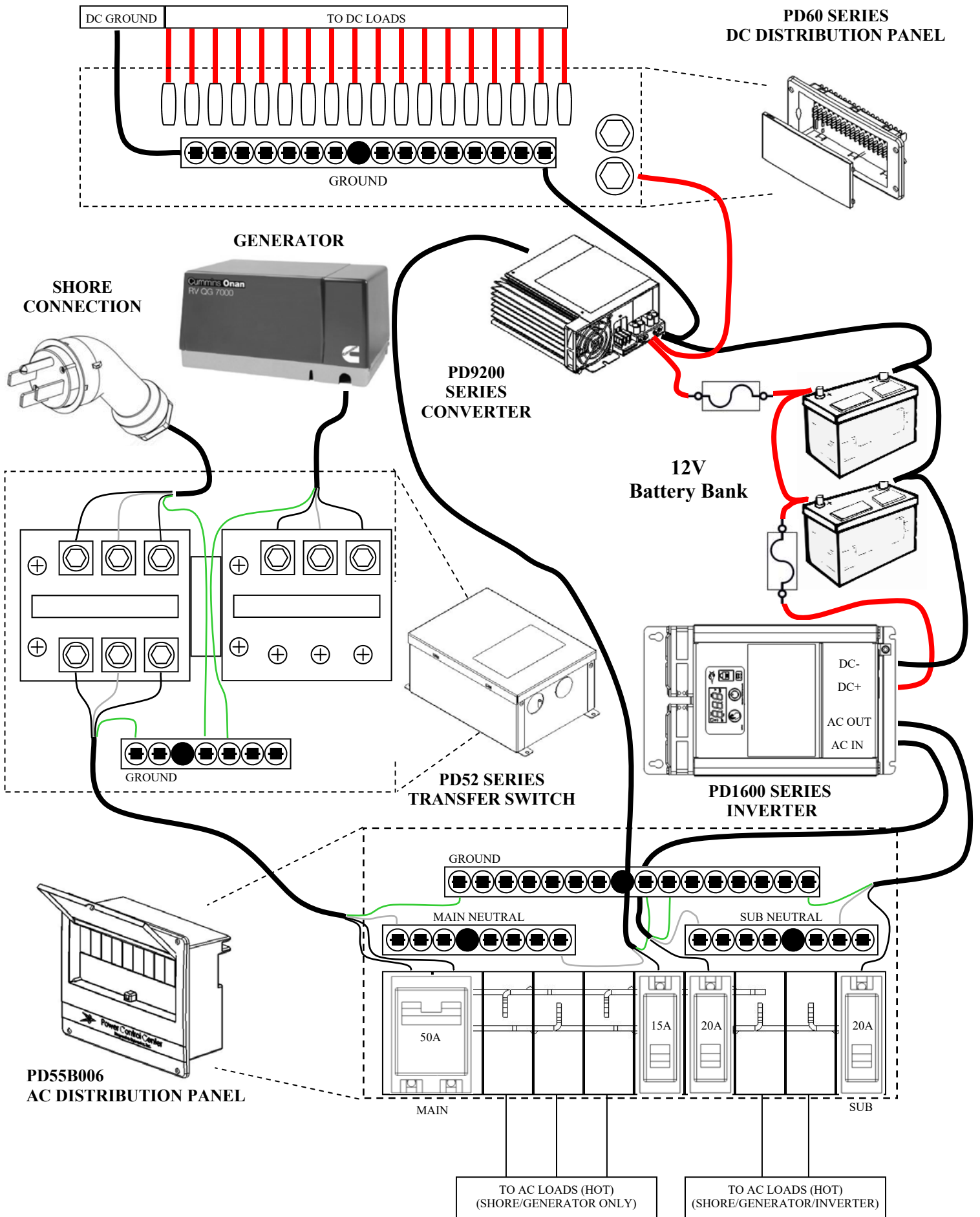

Choosing a Location For Your Inverter

Installation Location Requirements

The PD1600 Series Inverter should only be installed in locations that meet the following requirements:

- **Dry:** The inverter should be installed in a compartment separated from the outside environment to avoid exposure to rain, drips, and splashes that may damage the unit. The compartment should not contain water or other fluids.
- **Cool:** Air temperature of the inverter compartment should be between 4 degrees Fahrenheit and 104 degrees Fahrenheit (-20 degrees Celsius and 40 degrees Celsius). Higher temperatures will result in a reduction of performance.
- **Ventilated:** Do not block the opening for the fan. Do not allow the ventilation openings on the ends of the unit to become obstructed. The inverter compartment should not be used for storage of any kind to maximize ventilation space. Inverter should be located in a well ventilated compartment. Minimum compartment dimensions provide 2” of space above the inverter display and open on the electrical connection side. Operation in high ambient temperatures require additional ventilation space.
- **Separated from Batteries and Flammable Materials:** The PD1600 Series Inverter is not ignition protected. Do not mount the inverter in the liquid propane gas compartment, battery compartment, or any other compartment that may contain sparks or flammable materials.
- **Adjacent to the Battery Compartment:** It is required that the battery compartment is separate from the inverter compartment, but the compartments should be adjacent to one another. Do not place the battery compartment directly above the inverter compartment to avoid the potential for battery acid drips. In order to reduce cable losses and maximize system performance the DC input wires should be kept as short as possible. See Page 10 for recommended DC input wire sizes and lengths.
- **Orientated Properly:** It is recommended that the PD1600 series inverter is mounted horizontally (with the display facing up). The PD1600 series inverter may also be mounted vertically (with the AC/DC access panel facing down). In vertical installation care should be taken to avoid debris from falling into the inverter. For vertical installations it is recommended that a debris shield is installed 3 inches above the fan panel to block debris from falling into the inverter while allowing adequate air flow.

 WARNING: FIRE, SHOCK, OR ENERGY HAZARD
Inverter should only be installed by an electrician or a certified RV technician.
Inverter is NOT ignition protected. Do not mount in the LP gas or battery compartments
Inverter should be mounted in a dry, well ventilated space with adequate air flow
Failure to follow these instructions may result in serious injury or death. Failure to follow these instructions may also damage the unit and/or equipment.

RECOMMENDED GFCI's FOR USE PD1600 SERIES INVERTER.

The PD1600 series inverters have been tested and are compatible with the following Ground-Fault-Circuit-Interrupter (GFCI) receptacles. It is recommended that the PD1600 series inverter be used in conjunction with those listed below, for best performance. Other types may fail to operate properly when connected to this inverter.

Recommended GFCI for use with inverter:

Leviton GFTR2, Eaton SGF20, Bestten USP-20A-20-PKB, Hongki TST20

Mounting Instructions

1. Remove the PD1600 Series Inverter from its packaging, verify that all components are present, and record the inverter serial number in the quick reference guide contained within.
2. Select an appropriate mounting location and orientation (See Page 8 for additional details regarding acceptable installation practices).
3. Use the inverter as a drill guide by placing it flush against the mounting surface and marking the appropriate hole locations in the mounting surface (see Figure 4). Horizontal mounting of the PD1600 Series Inverter is recommended (see Figure 6), although it can be mounted in a vertical position that provides unobstructed ventilation to the fan and vent holes.
4. If mounting vertically, mount the PD1600 Series Inverter that the wiring compartment is facing down (see Figure 5). This will ensure that the display will be oriented correctly. It is best to ensure that PD1600 series inverter is placed in an area that keep dust & debris from entering the fan area. Debris may cause unexpected performance issues in your inverter.
5. Pilot-drill the mounting holes in the marked locations
6. Secure the PD1600 Series Inverter firmly to the mounting surface using standard fasteners

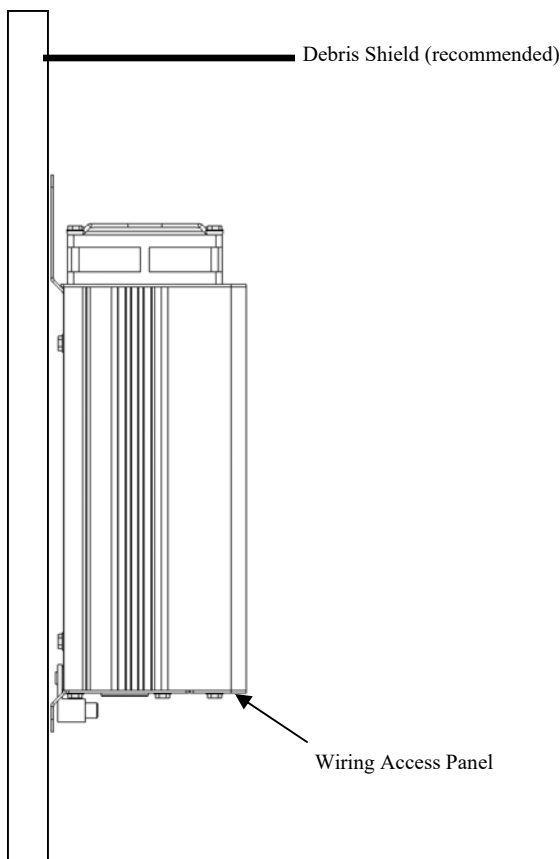

Figure 5 Vertical Mounting Configuration

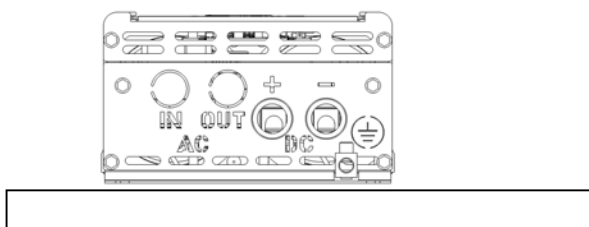



Figure 6 Horizontal Mounting Configuration

WARNING: FIRE, SHOCK, AND ENERGY HAZARD
Inverter should only be installed by an electrician or a certified RV technician.
 Inverter is NOT ignition protected. Do not mount in the LP gas or battery compartments
Inverter should be mounted in a dry, well ventilated space with adequate air flow
Failure to follow these instructions may result in serious injury or death. Failure to follow these instructions may also damage the unit and/or equipment.

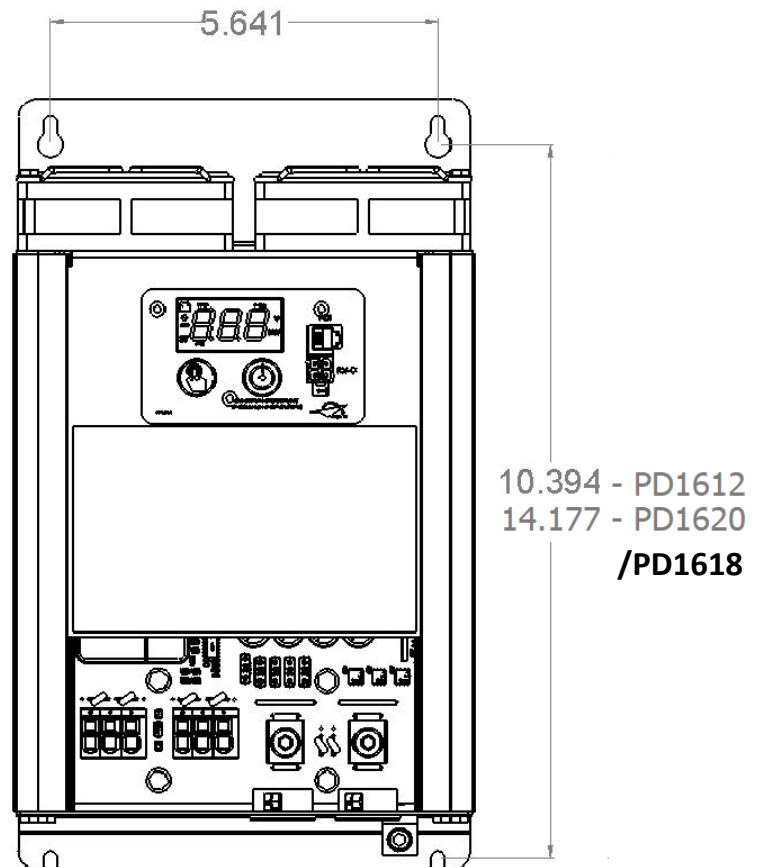

Figure 7 Inverter Mounting Hole Pattern

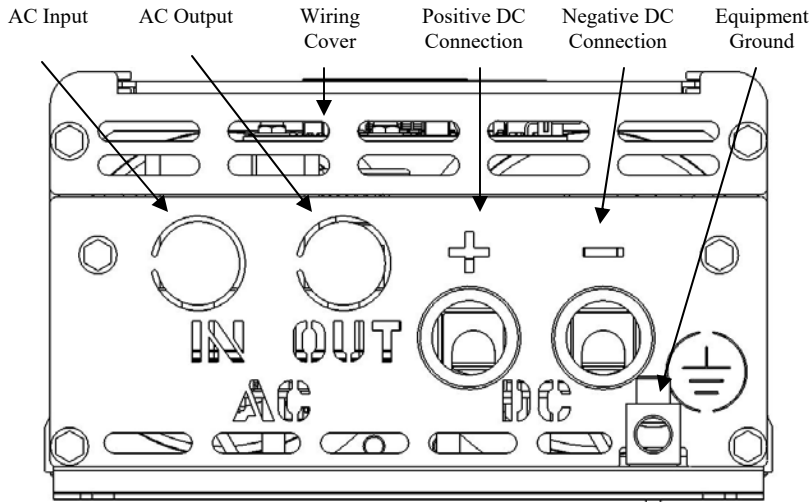

Figure 8 Electrical Connections Side View

PD1600 series Inverters are compatible with **BOTH** Lithium and Lead Acid batteries.

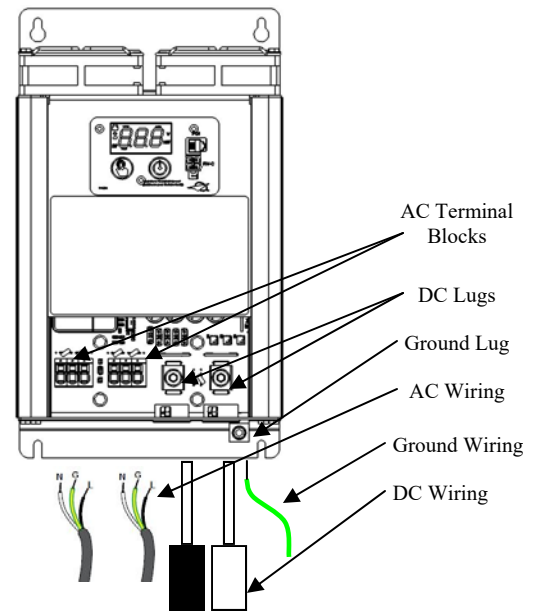

Figure 9 Electrical Connections Top View

ELECTRICAL CONNECTION INFORMATION					
		WIRE LENGTH	MIN. WIRE SIZE	STRIP LENGTH	CONNECTION INFO
DC WIRING	PD1610(1kW)	0-5 ft.	#2 AWG	Strip 3/4" (19 mm) insulation from each cable prior to installation. Do not leave excess copper exposed.	Tighten lugs to a torque of 100 in-lbs (11.3 N-m). <u>Do not over tighten.</u>
		5-10 ft.	#1 AWG		
		10-15 ft.	#1/0 AWG		
	PD1618(1.8kW)	0-10 ft.	#2/0 AWG	Strip 3/4" (19 mm) insulation from each cable prior to installation. Do not leave excess copper exposed.	Tighten lugs to a torque of 200 in-lbs (22.6 N-m). <u>Do not over tighten.</u>
PD1620(2kW)	0-10 ft.	#2/0 AWG			
AC WIRING	PD1610(1kW)	0-100 ft.	#14 AWG Solid	Strip 0.6" (15 mm) insulation from each wire prior to installation. Do not leave excess copper exposed.	Standard 3/8" trade strain relief . No torque wrench required
	PD1618(1.8kW)	0-100 ft.	#14 AWG Solid		
	PD1620(2kW)	0-100 ft.	#12 AWG Solid		
GND WIRING	PD1600 Series	Any	#8 AWG	Strip 0.5" (13 mm) insulation from each wire prior to installation. Do not leave excess copper exposed.	Torque ground lug to 30-50 in-lbs.

NOTE: To ensure optimum performance all input wires should be as short as possible. Failure to meet minimum recommended wire size will result in reduced performance

Electrical Connection Instructions

1. Ensure all power sources are disconnected from the inverter
2. Remove the Wiring Cover
3. Remove AC Input knockouts and AC Output knockouts
4. Install 3/8" strain relief in AC Input and AC Output ports
5. Connect AC Out terminal block (Ground, Neutral, and Line)
6. Connect AC In terminal block (Ground, Neutral, and Line)
7. Tighten strain relief (if applicable)
8. Connect DC terminals (positive and negative) to battery with properly sized wires using a 5/32" hex key
9. When connecting DC wires a small spark may occur. This is normal charging of the inverter's internal capacitors
10. Provide external strain relief for DC wires
11. Connect equipment ground stud to a grounding point (typically the vehicle's chassis) using a 5/32" hex key
12. Re-install the Wiring Cover

⚠ WARNING: FIRE, SHOCK, AND ENERGY HAZARD

Make sure wiring is disconnected from all electrical sources before handling. All wiring must be done in accordance with local and national electrical wiring codes.

Failure to follow these instructions may result in serious injury or death.

The PD1600 Series Inverter includes knockouts for use with a standard 3/8" trade size strain relief. Use of a strain relief is required when hard wiring your inverter. Neglecting to use a strain relief may cause undue stress and fatigue to the wiring connections on your unit. PDI lists examples of some commonly utilized types of strain relief. Strain reliefs are not provided with purchase of the inverter, and must be provided by installer at the time of installation.

Push-In Style



Halex #27510 or equivalent

- 3/8" trade size push-in connector-
- Material: Plastic
- Installation Instructions
 1. Insert strain relief into 3/8" trade size opening
 2. Push wire into slotted opening the desired distance
 3. Push stripped wires into terminals blocks
 4. Install wiring into terminal blocks

Metal Clamp Style



Halex #20570 or equivalent

- 3/8" trade size clamp combination connector
- Material: Zinc plated metal
- Installation Instructions
 1. Insert strain relief into 3/8" trade size opening
 2. Slide wire through central opening
 3. Push stripped wires into terminals blocks
 4. Tighten the strain relief using screws on the side

Plastic Clamp Style



Halex #27515 or equivalent

- 3/8" trade size clamp combination connector
- Material: Plastic
- Installation Instructions
 1. Insert strain relief into 3/8" trade size opening
 2. Slide wire through central opening
 3. Push stripped wires into terminals blocks
 4. Tighten the strain relief by sliding retention clip into the slot

Figure 10 Recommend Strain Relief

The type of 3/8" trade size strain relief used is ultimately at the discretion of the installer. PDI can only recommend types of strain relief for end use, and is not responsible for any misuse or absence of strain relief at installation.



Figure 11 Display Panel

Display Features

- Power Button: Press to turn on; hold to turn off
- Select Button: Cycles between display states: Input Voltage, Output Voltage, Output Power, Sleep, Error Code (if applicable)
- Power Indicator: Lights up green when the inverter is on
- Fault Indicator: Flashes red when an error has occurred
- Shore Indicator: Lights up yellow when AC input is detected
- Low Bat Warning Indicator: Lights up red when the battery is nearing the end of its charge
- Sleep: Lights automatically dim after 30 seconds
- Remote port for externally mounted display

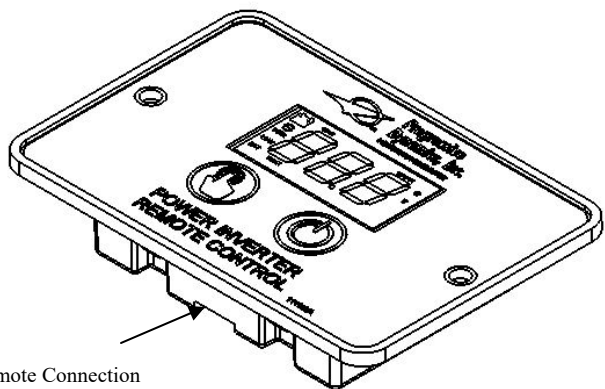

Figure 12 PD1601 Remote Display

NOTE: Remote display operates exactly the same as the display mounted to the inverter

ERROR CODES		
Error Code	Condition	Description
E-1	Low battery voltage detected	Input voltage has dropped beneath 10.5V for several seconds. The PD1600 Series inverter will automatically restart when the input voltage reaches 12.0V.
E-2	High battery voltage shutdown	Input voltage has surpassed 15.5V. The PD1600 Series inverter will automatically restart when the input voltage falls below 15.0V.
E-3	AC output overload shutdown	Output power has surpassed the continuous power limit or the peak power limit. The PD1600 Series inverter will not automatically restart. A manual restart is necessary
E-4	Over-temperature shutdown	Internal temperature of the inverter has exceeded its safe operating limit. The PD1600 Series inverter will automatically restart when internal temperatures return to safe operating conditions.
E-5	Internal Error	An internal error has been detected. The PD1600 Series inverter will not automatically restart. A manual restart is necessary
E-6	Short Circuit	A short circuit has been detected on the AC output of the inverter. The inverter will not restart. A manual restart is necessary.

Figure 13 Error Code Descriptions

NOTE: For troubleshooting error codes, consult page 14

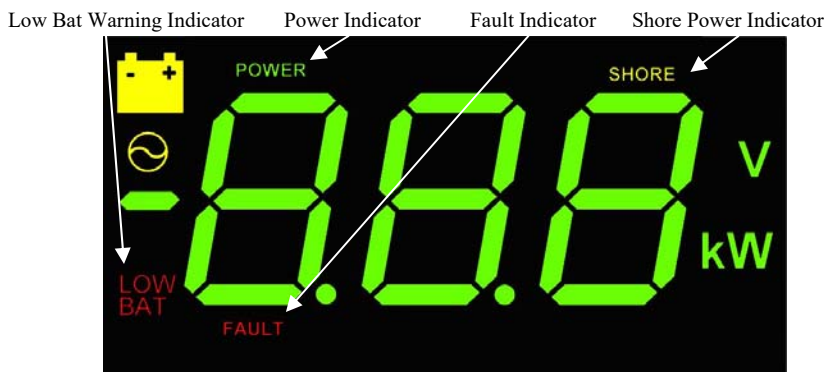
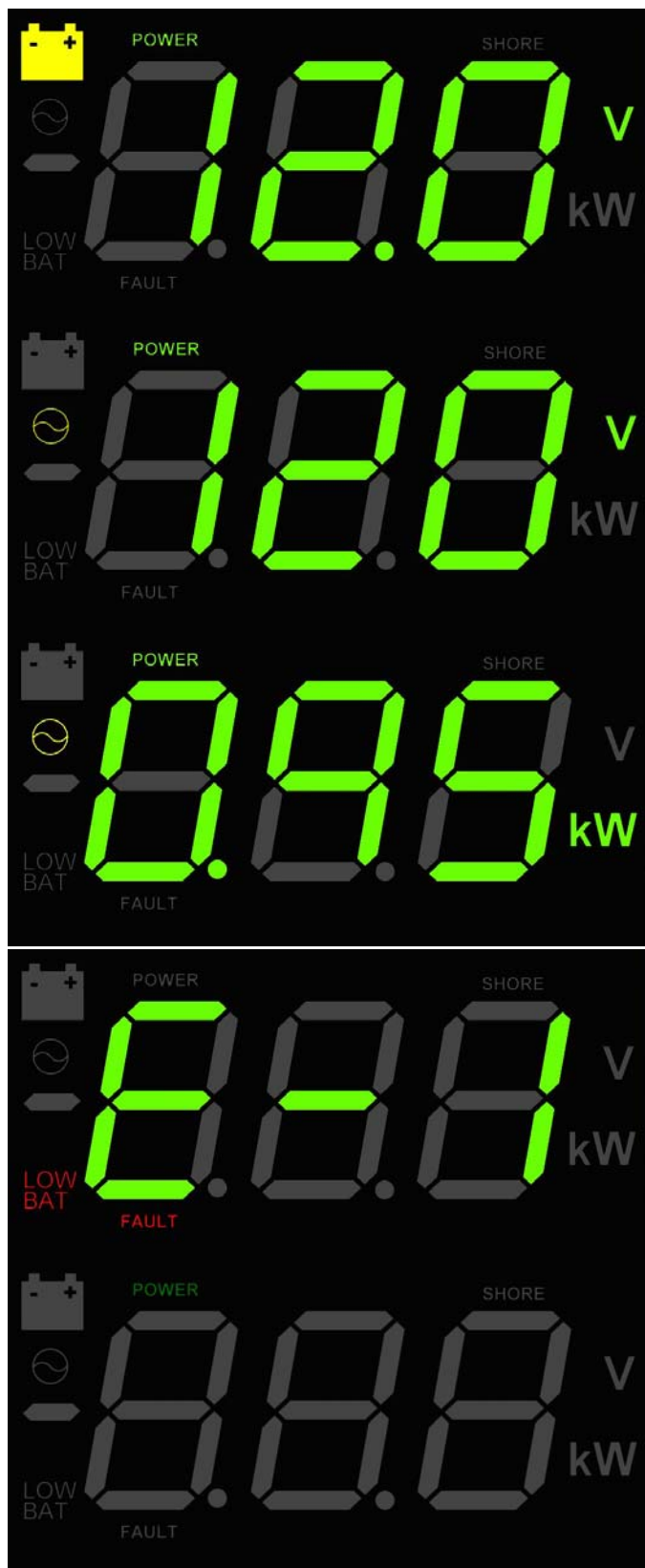

Figure 14 Display Indicators



DC Input Voltage

- Battery indicator is illuminated
- Volts indicator is illuminated
- DC Input Voltage measurement is always available
- DC Input Voltage measurement is the default display state on start up

AC Output Voltage

- AC indicator is illuminated
- Volts indicator is illuminated
- AC Output Voltage measurement is available only when the inverter is supplying power (not when the inverter is in shore power mode)

AC Output Power

- AC indicator is illuminated
- kW indicator is illuminated
- AC Output Power measurement is available only when the inverter is supplying power (not when the inverter is in shore power mode)

Error

- Error code display is only available if the inverter is currently in an error state.
- See Figure 13 for error code descriptions
- See page 14 for troubleshooting guide if error code persists

Sleep

- Only indicators that may be illuminated are: Power, Shore, Fault, and Low Battery
- Indicators in sleep mode will be noticeably dimmer than in any other state
- The PD1600 Series Inverter display automatically enters sleep mode when neither of the control buttons have been pressed for 30 seconds
- The inverter will automatically exit sleep mode when any error occurs or shore power is detected
- To manually exit sleep mode press either button. Pressing the power button will not turn off the inverter; it must be held for 5 seconds to power down.

Figure 15 Display States

NOTE: To cycle through the display states simply press the select button. Display states cycle in order as listed on this page. The display will skip un-available display states (see display state descriptions above for additional details).

Troubleshooting Guide	
Symptom	Corrective Actions
PD1600 Series Inverter has a flashing fault light	The inverter has detected a fault condition. 30 Seconds after the fault condition is detected the display enters sleep mode. <ul style="list-style-type: none"> • Press the select button to view the error code. Press the select button again to view the battery voltage. Proceed to the correct troubleshooting action below.
E-1 is displayed	The input voltage fell below 10.5 VDC. Inverter will automatically restart when DC Input voltage is increased to 12.0VDC <ul style="list-style-type: none"> • Re-charge batteries to at least 12.0VDC. • Ensure all DC input connections are tightened
Inverter is turning on and off. E-1 is displayed when it is off	Likely, the batteries are nearly fully discharged. When a heavy load is being drawn from a battery the battery voltage will droop causing an under voltage error. Then with the inverter turned off the battery voltage will slowly drift back up because there is no load on the batteries. If the battery voltage drifts back up to 12.0VDC the inverter will turn back on. This cycle may repeat several times. This behavior will be seen more often with batteries nearing the end of life. <ul style="list-style-type: none"> • Re-charge batteries to at least 12.0VDC. • Ensure all DC input connections are tightened • Make sure DC input wire size and length comply with minimum wire size diameter. • Replace batteries
Batteries are fully charged. Inverter displays E-1 immediately after it is turned on	The batteries may be fully charged, but if the battery voltage is not properly connected to the DC Input terminals of the inverter a low battery fault may be falsely triggered. <ul style="list-style-type: none"> • Ensure all DC input connections are tightened • Make sure DC input wire size and length comply with Figure 15
E-2 is displayed	The input voltage has exceeded 15.5VDC. Inverter will automatically restart when DC Input voltage is decreased to 15.0VDC <ul style="list-style-type: none"> • Turn off the inverter by holding down the power button. Locate DC source and verify it is properly connected for 12VDC operation
E-3 is displayed	An over-load condition has been detected. This can be excessive power or a peak power that exceed 2X rated power. A manual restart is required after the over-load issue has been resolved. <ul style="list-style-type: none"> • Check output wiring for a short circuit. • Determine what loads are connected to the output of the inverter. Remove un-necessary loads until power is below maximum rated power.
E-4 is displayed	An over temperature condition has occurred. The inverter will automatically restart when the internal temperature falls to safe operating conditions. <ul style="list-style-type: none"> • Ensure that debris hasn't fallen into the fan opening blocking its operation • Remove items surrounding the inverter to ensure adequate air flow. • Move inverter to a well ventilated space. • Lower ambient air temperature to room temperature.
Inverter is turning on and off. E-4 is displayed when it is off	An over temperature condition has occurred. The inverter will automatically restart when the internal temperature falls to safe operating conditions. <ul style="list-style-type: none"> • Ensure that debris hasn't fallen into the fan opening blocking its operation • Remove items surrounding the inverter to ensure adequate air flow. • Move inverter to a well ventilated space. • Lower ambient air temperature to room temperature.
Inverter is making a buzzing sound	A buzzing sound may be produced during large surges in output power. This will most commonly be observed on some refrigerators when the compressor is starting up. This buzzing sound is normal and should not last for more than 2 seconds.

<p>For further assistance contact :</p> <p>PDI Service Department service@progressivedyn.com</p>	<p> WARNING: FIRE, SHOCK, OR ENERGY HAZARD</p> <p>DO NOT disassemble the inverter. It does not contain any user serviceable parts. Attempting to service the unit yourself could result in an electrical shock or burn.</p> <p>Failure to follow these instructions may result in serious injury or death.</p>
--	---

Troubleshooting Guide	
Symptom	Corrective Actions
E-5 is displayed	During startup the inverter draws a small amount of current to charge the input capacitors. If that current exceeds a normal range the inverter shuts down and reports an internal error. This is can be indicative of bad input wiring or an internal failure. <ul style="list-style-type: none"> • Ensure all DC input connections are tightened • Make sure DC input wire size and length comply with Figure 15
E-6 is displayed	A short circuit has been detected on the AC output of the inverter. <ul style="list-style-type: none"> • Check the AC wiring to make sure that wires aren't touching each other • Check each AC load for failure • Determine surge requirements for AC loads. Motorized loads may draw peak power greater than the peak power rating
Inverter is off. Nothing happens with power button is pressed	Likely, DC Input power is not being properly applied to the DC input terminals. <ul style="list-style-type: none"> • Ensure all DC input connections are tightened • Ensure that all any external DC disconnect switches are in the on position • Ensure that the DC input wires are connected to positive and negative correctly (not reversed) • If using the remote display panel, make sure that it is connected to the inverter using the provided 25' cable.
Inverter turned off for seemingly no reason	Something has interrupted the communication between the display and the inverter. <ul style="list-style-type: none"> • Ensure that the equipment ground wire is properly secured to the equipment ground lug

For Further Assistance Contact:

PDI Service Department:
service@progressivedyn.com

WARNING: FIRE, SHOCK, OR ENERGY HAZARD

DO NOT disassemble the inverter. It does not contain any user serviceable parts. Attempting to service the unit yourself could result in an electrical shock or burn.

Failure to follow these instructions may result in serious injury or death.

SPECIFICATIONS

PHYSICAL SPECIFICATIONS				TRANSFER SWITCH			
	PD1610	PD1618	PD1620		PD1610	PD1618	PD1620
Dimensions	L:11.2"(284mm)	L:15.0"(381mm)	L:15.0"(381mm)	Transfer Voltage	95 - 135 VAC		
	W:6.7"(170mm)	W:7.9"(200mm)	W:7.9"(200mm)				
	H:4.0"(101mm)	H:4.0"(101mm)	H:4.0"(101mm)	Pass Through Ampacity	20 AAC		
Net Weight	7 lbs (3.2 kg)	11 lbs (5.0 kg)	11 lbs (5.0 kg)				
AC OUTPUT				DC INPUT			
	PD1610	PD1618	PD1620		PD1610	PD1618	PD1620
Waveform	Pure Sine Wave			Nominal Voltage	12.0 VDC		
Output Voltage	120 VAC			Under-Voltage Shutdown	10.5 VDC		
Max Power (Cont)	1000W	1800W	2000W	Under-Voltage Restart	12.0 VDC		
Max Power (Peak)	2000W	3600W	4000W	Over-Voltage Shutdown	15.5 VDC		
Frequency	60 Hz			Over-Voltage Restart	15.0 VDC		
Peak Efficiency	90%			Max Current @ max load	100 ADC	180 ADC	200 ADC

*All ratings at 25 °C unless otherwise listed



Figure 16 RV-C Comm Port

RV-C Introduction

The PD1600 Series Inverter was designed to include RV-C communications capability. RV-C is an industry developed communications protocol that is used in many RV multiplexing systems. The PD1600 Series Inverters were released with limited functionality to turn on/off the inverter and report back basic operating parameters. Additional functionality will be added to the PD1600 Series Inverters as required to operate with modern RV multiplexing systems. See chart below for the current list of compatible Data Groups.

PD1600 Series Inverter RV-C Compatible Data Groups		
Data Group	Periodic Send	Description
Product ID	n/a	When requested the inverter responds with the make and model "Progressive Dynamics * PD1600 Series vX.XX"
DM RV	4 seconds	Provides information on Service Points in the event of a fault
Address Claimed	n/a	When prompted the inverter indicates that it has a static address compatible with RV-C.
Inverter AC Output Page 1	0.1 seconds	Provides information on AC output frequency and voltage
Inverter AC Output Page 2	0.1 seconds	Provides information on AC bypass ampacity
Inverter AC Output Page 3	0.1 seconds	Provides information on AC waveform and AC output power
Inverter AC Output Page 4	0.1 seconds	Data Group not yet implemented
Inverter Status	0.5 seconds	Provides inverter status: Disabled, Inverter, AC Pass-through
DC Status	4 seconds	Provides information on DC input voltage
Inverter Command	n/a	Accepts command to turn on/off the inverter